

Features

- ◆ Broad Bandwidth Specified up to 18 GHz
- ◆ Usable up to 26 GHz
- ◆ Integrated Bias Network
- ◆ Low Insertion Loss / High Isolation
- ◆ Rugged,
- ◆ Fully Monolithic
- ◆ Glass Encapsulate Construction

Description

The MASW-002102-13580 and MASW-003102-13590 devices are SP2T and SP3T broad band switches with integrated bias networks utilizing M/A-COM's HMIC™ (Heterolithic Microwave Integrated Circuit) process, US Patent 5,268,310. This process allows the incorporation of silicon pedestals that form series and shunt diodes or vias by imbedding them in low loss, low dispersion glass. By using small spacing between elements, this combination of silicon and glass gives HMIC devices low loss and high isolation performance with exceptional repeatability through low millimeter frequencies. Large bond pads facilitate the use of low inductance ribbon bonds, while gold backside metallization allows for manual or automatic chip bonding via 80/20 - Au/Sn, 62/36/2 - Sn/Pb/Ag solders or electrically conductive silver epoxy.

Parameter	Absolute Maximum
Operating Temperature	-65°C to +125°C
Storage Temperature	-65°C to +150°C
Junction Temperature	+175°C
Applied Reverse Voltage	50V
RF Incident Power	+33dBm C.W.
Bias Current +25°C	±20mA

Max. operating conditions for a combination of RF power, D.C. bias and temperature:

+33dBm CW @ 15mA (per diode) @+85°C

MASW-002102-13580

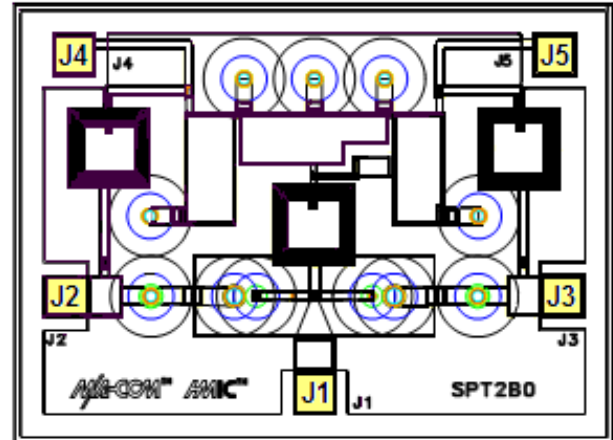

MASW-003102-13590

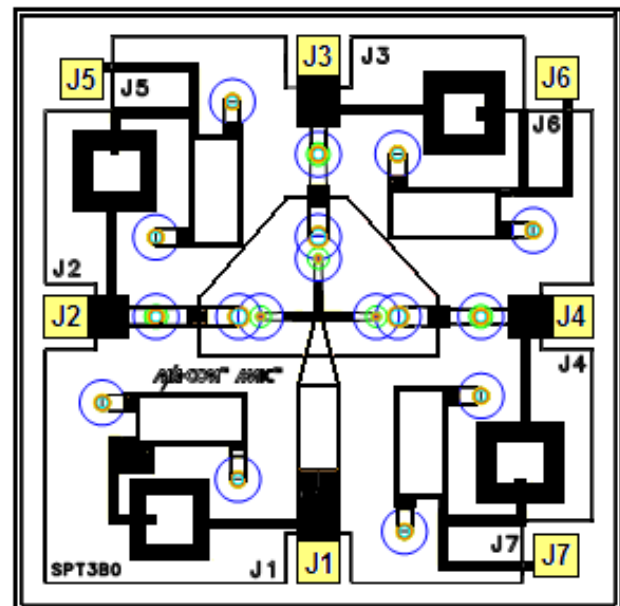

Yellow areas denote wire bond pads

ADVANCED: Data Sheets contain information regarding a product M/A-COM is considering for development. Performance is based on target specifications, simulated results, and/or prototype measurements. Commitment to develop is not guaranteed.

PRELIMINARY: Data Sheets contain information regarding a product M/A-COM has under development. Performance is based on engineering tests. Specifications are typical. Mechanical outline has been fixed. Engineering samples and/or test data may be available. Commitment to produce in volume is not guaranteed.

- **North America** Tel: 800.366.2266 / Fax: 978.366.2266
- **Europe** Tel: 44.1908.574.200 / Fax: 44.1908.574.300
- **Asia/Pacific** Tel: 81.44.844.8296 / Fax: 81.44.844.8298

Visit www.macom.com for additional data sheets and product information.

M/A-COM Inc. and its affiliates reserve the right to make changes to the product(s) or information contained herein without notice.

MASW-002102-13580 (SPDT)
Electrical Specifications @ T_{AMB} = +25°C, 20mA Bias current

Parameter	Frequency	Minimum	Nominal	Maximum	Units
Insertion Loss	2 GHz		1.5	1.8	dB
	6 GHz		0.70	1.0	dB
	12 GHz		0.90	1.2	dB
	18 GHz		1.2	1.8	dB
Isolation	2 GHz	55	60		dB
	6 GHz	47	50		dB
	12 GHz	40	45		dB
	18 GHz	36	40		dB
Input Return Loss	2 GHz		14		dB
	6 GHz		15		dB
	12 GHz		15		dB
	18 GHz		13.0		dB
Switching Speed ¹	-		50		ns

MASW-003102-13590 (SP3T)
Electrical Specifications @ T_{AMB} = +25°C, 20mA Bias current

Parameter	Frequency	Minimum	Nominal	Maximum	Units
Insertion Loss	2 GHz		1.6	2.0	dB
	6 GHz		0.8	1.1	dB
	12 GHz		1.0	1.3	dB
	18 GHz		1.3	1.9	dB
Isolation	2 GHz	54	59		dB
	6 GHz	47	50		dB
	12 GHz	40	45		dB
	18 GHz	36	40		dB
Input Return Loss	2 GHz		14		dB
	6 GHz		15		dB
	12 GHz		16		dB
	18 GHz		14		dB
Switching Speed ¹	-		50		ns

Note:

1. Typical switching speed measured from 10% to 90% of detected RF signal driven by TTL compatible drivers using RC output spiking network, R = 50 – 200Ω , C = 390 – 560pF.

ADVANCED: Data Sheets contain information regarding a product M/A-COM is considering for development. Performance is based on target specifications, simulated results, and/or prototype measurements. Commitment to develop is not guaranteed.

PRELIMINARY: Data Sheets contain information regarding a product M/A-COM has under development. Performance is based on engineering tests. Specifications are typical. Mechanical outline has been fixed. Engineering samples and/or test data may be available. Commitment to produce in volume is not guaranteed.

- **North America** Tel: 800.366.2266 / Fax: 978.366.2266
- **Europe** Tel: 44.1908.574.200 / Fax: 44.1908.574.300
- **Asia/Pacific** Tel: 81.44.844.8296 / Fax: 81.44.844.8298

Visit www.macom.com for additional data sheets and product information.

M/A-COM Inc. and its affiliates reserve the right to make changes to the product(s) or information contained herein without notice.

Typical RF Performance at $T_A = +25^\circ\text{C}$, 20mA Bias Current

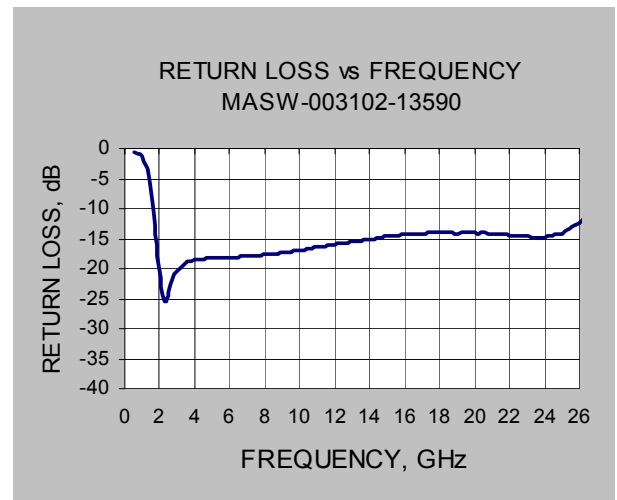
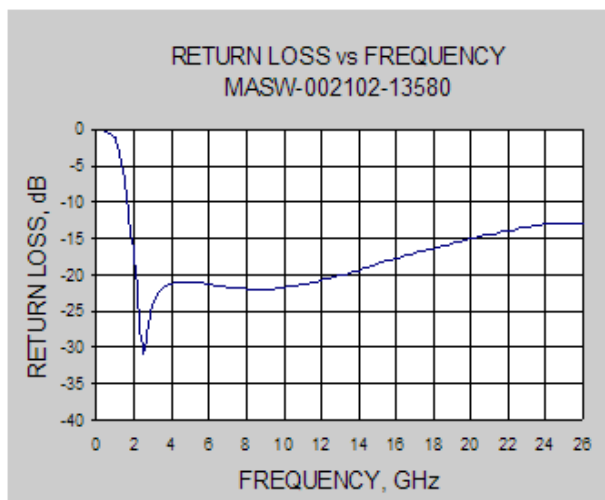
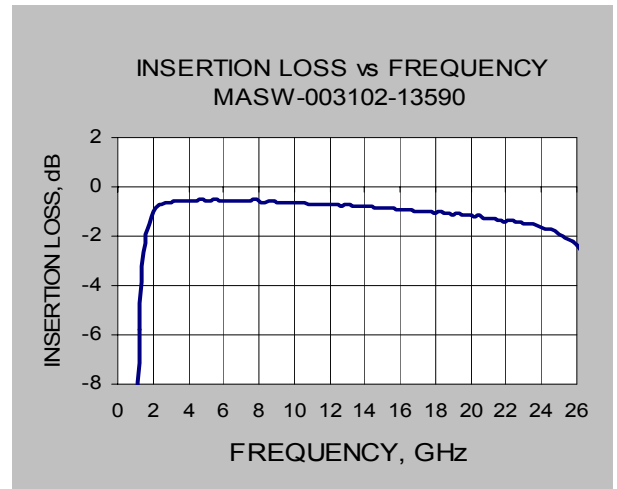
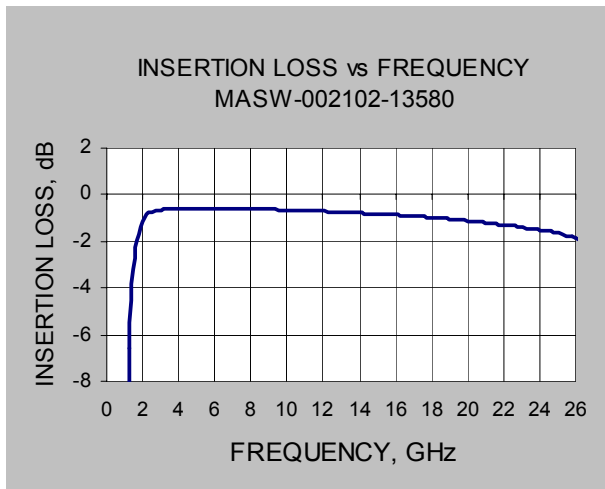
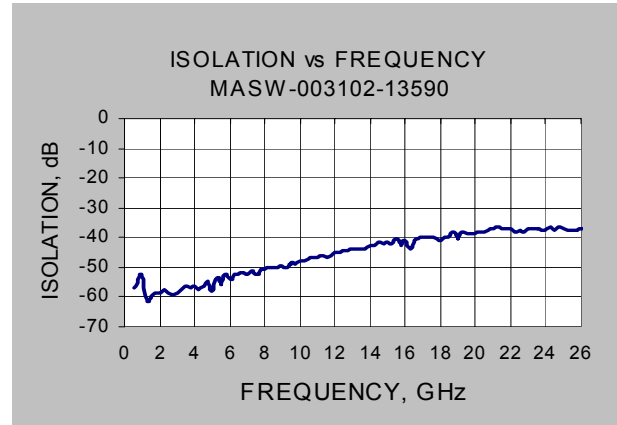
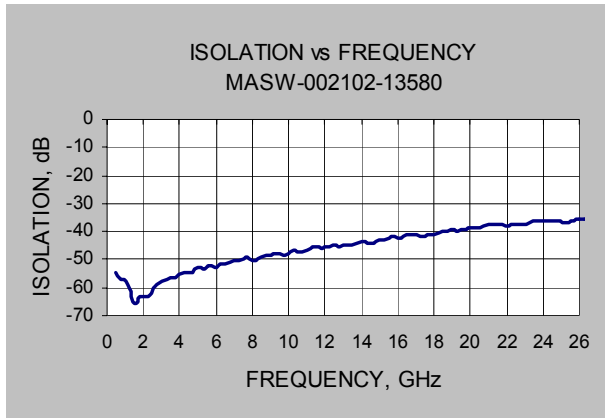

ADVANCED: Data Sheets contain information regarding a product M/A-COM is considering for development. Performance is based on target specifications, simulated results, and/or prototype measurements. Commitment to develop is not guaranteed.

PRELIMINARY: Data Sheets contain information regarding a product M/A-COM has under development. Performance is based on engineering tests. Specifications are typical. Mechanical outline has been fixed. Engineering samples and/or test data may be available. Commitment to produce in volume is not guaranteed.

- **North America** Tel: 800.366.2266 / Fax: 978.366.2266
- **Europe** Tel: 44.1908.574.200 / Fax: 44.1908.574.300
- **Asia/Pacific** Tel: 81.44.844.8296 / Fax: 81.44.844.8298

Visit www.macom.com for additional data sheets and product information.

M/A-COM Inc. and its affiliates reserve the right to make changes to the product(s) or information contained herein without notice.

MASW-002102-13580 Junction Temperature vs. Incident Power at 8 GHz

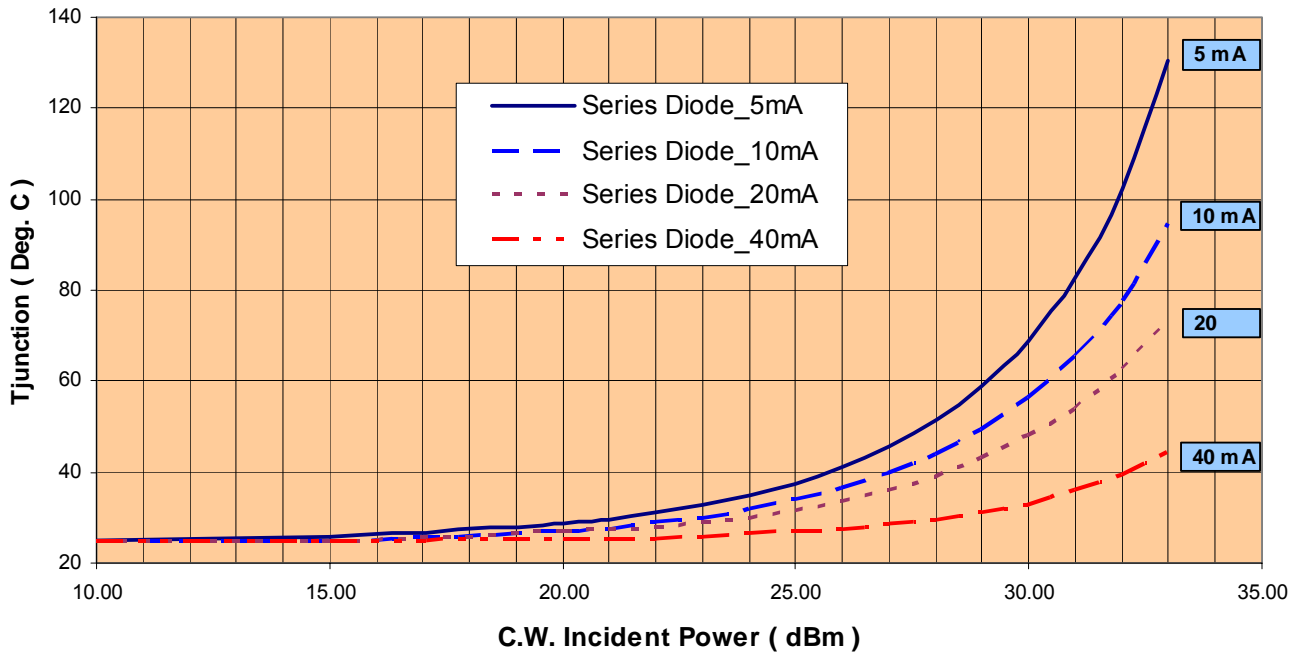

MASW-002102-13580 Compression Power vs. Incident Power at 8 GHz

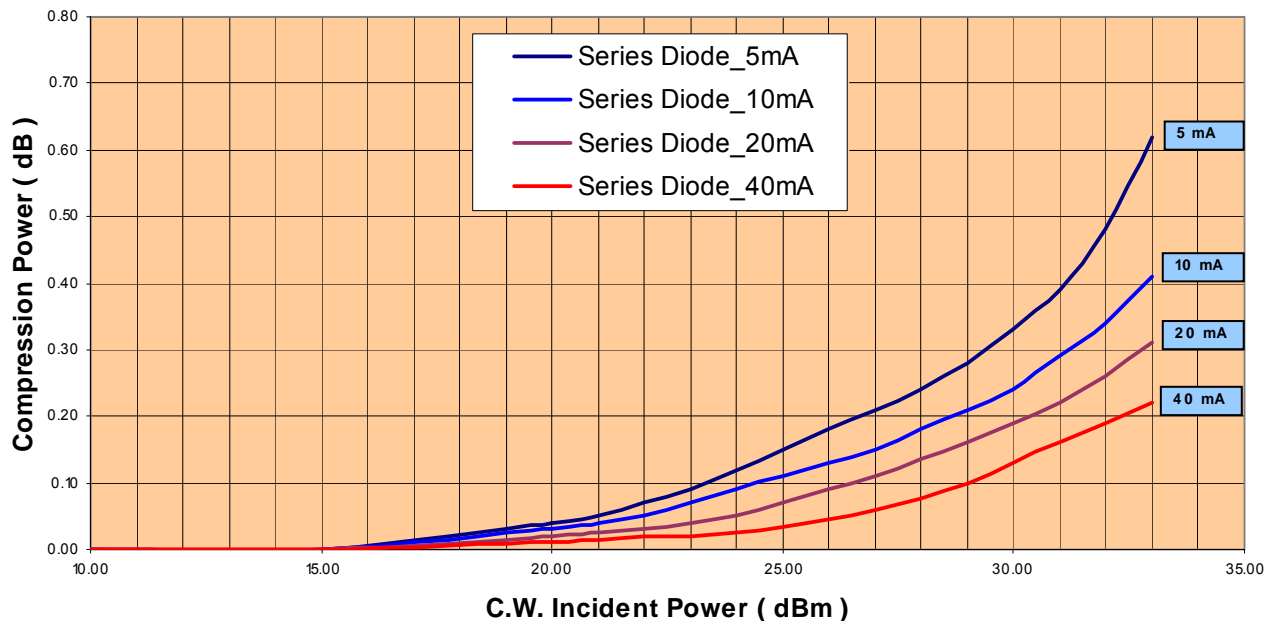

Note:

The PIN diodes in the MASW-002102-13580 and the MASW-003102-13590 have the same electrical characteristics and will have similar performance.

ADVANCED: Data Sheets contain information regarding a product M/A-COM is considering for development. Performance is based on target specifications, simulated results, and/or prototype measurements. Commitment to develop is not guaranteed.

PRELIMINARY: Data Sheets contain information regarding a product M/A-COM has under development. Performance is based on engineering tests. Specifications are typical. Mechanical outline has been fixed. Engineering samples and/or test data may be available. Commitment to produce in volume is not guaranteed.

- **North America** Tel: 800.366.2266 / Fax: 978.366.2266
- **Europe** Tel: 44.1908.574.200 / Fax: 44.1908.574.300
- **Asia/Pacific** Tel: 81.44.844.8296 / Fax: 81.44.844.8298

Visit www.macom.com for additional data sheets and product information.

M/A-COM Inc. and its affiliates reserve the right to make changes to the product(s) or information contained herein without notice.

Operation of the MASW-002102-13580 and MASW-003102-13590

Operation of the MASW-002102-13580 and MASW-003102-13590 PIN diode switches is achieved by simultaneous application of DC currents to the bias pads. The required levels for the different states are shown in the tables below. The control currents should be supplied by constant current sources. The nominal 40Ω - 60Ω pull-up resistor voltage @ J4 and J5 and for -20mA is usually -1V for +20mA is usually +1V.

Driver Connections MASW-002102-13580

Control Level I_{DC} @		Condition of RF Output	Condition of RF Output
J4	J5	J1 - J2	J1 - J3
-20mA	+20mA	Low Loss	Isolation
+20mA	-20mA	Isolation	Low Loss

Driver Connections MASW-003102-13590

Control Level I_{DC} @			Condition of RF Output	Condition of RF Output	Condition of RF Output
J5	J6	J7	J1 - J2	J1 - J3	J1 - J4
-20mA	+20mA	+20mA	Low Loss	Isolation	Isolation
+20 mA	-20mA	+20mA	Isolation	Low Loss	Isolation
+20mA	+20mA	-20mA	Isolation	Isolation	Low Loss

Equivalent Circuit MASW-002102-13580

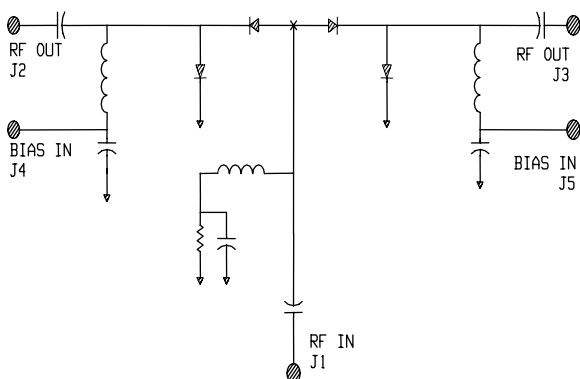

Equivalent Circuit MASW-003102-13590

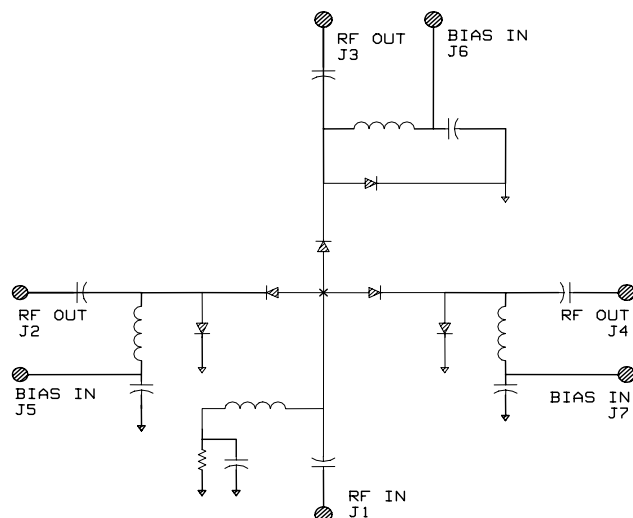

ADVANCED: Data Sheets contain information regarding a product M/A-COM is considering for development. Performance is based on target specifications, simulated results, and/or prototype measurements. Commitment to develop is not guaranteed.

PRELIMINARY: Data Sheets contain information regarding a product M/A-COM has under development. Performance is based on engineering tests. Specifications are typical. Mechanical outline has been fixed. Engineering samples and/or test data may be available. Commitment to produce in volume is not guaranteed.

- **North America** Tel: 800.366.2266 / Fax: 978.366.2266
- **Europe** Tel: 44.1908.574.200 / Fax: 44.1908.574.300
- **Asia/Pacific** Tel: 81.44.844.8296 / Fax: 81.44.844.8298

Visit www.macom.com for additional data sheets and product information.

M/A-COM Inc. and its affiliates reserve the right to make changes to the product(s) or information contained herein without notice.

Wire/Ribbon and Die Attachment Recommendations

Wire Bonding

Thermosonic wedge wire bonding using 0.00025" x 0.003" ribbon or 0.001" diameter gold wire is recommended. A heat stage temperature of 150°C and a force of 18 to 22 grams should be used. Ultrasonic energy should be adjusted to the minimum required to achieve a good bond. RF bond wires should be kept as short and straight as possible.

Mounting

The HMIC switches have Ti-Pt-Au back metal. They can be die mounted with a gold-tin eutectic solder preform or conductive epoxy. Mounting surface must be clean and flat.

Eutectic Die Attachment: An 80/20, gold-tin, eutectic solder preform is recommended with a work surface temperature of 255°C and a tool tip temperature of 265°C. When hot gas is applied, the tool tip temperature should be 290°C. The chip should not be exposed to temperatures greater than 320°C for more than 20 seconds. No more than three seconds should be required for attachment. Solders containing tin should not be used.

Epoxy Die Attachment: A minimum amount of epoxy should be used. A thin epoxy fillet should be visible around the perimeter of the chip after placement. Cure epoxy per manufacturer's schedule (typically 125-150°C).

MASW-002102-13580 Chip Outline Drawing^{1,2}

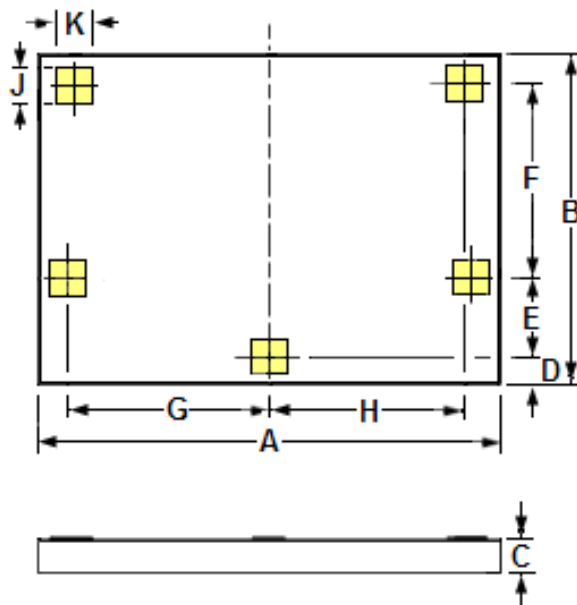

DIM	INCHES		MILLIMETERS	
	MIN	MAX	MIN	MAX
A	0.066	0.070	1.680	1.780
B	0.048	0.052	1.230	1.330
C	0.004	0.006	0.100	0.150
D	0.004	0.006	0.090	0.140
E	0.012	0.013	0.292	0.317
F	0.029	0.030	0.735	0.760
G	0.030	0.031	0.766	0.791
H	0.029	0.030	0.732	0.757
J	0.005	REF.	0.129	REF.
K	0.005	REF.	0.129	REF.

Notes:

1. Topside and backside metallization is gold, 2.5mm thick typical.
2. Yellow areas indicate wire bonding pads

ADVANCED: Data Sheets contain information regarding a product M/A-COM is considering for development. Performance is based on target specifications, simulated results, and/or prototype measurements. Commitment to develop is not guaranteed.

PRELIMINARY: Data Sheets contain information regarding a product M/A-COM has under development. Performance is based on engineering tests. Specifications are typical. Mechanical outline has been fixed. Engineering samples and/or test data may be available. Commitment to produce in volume is not guaranteed.

- **North America** Tel: 800.366.2266 / Fax: 978.366.2266
- **Europe** Tel: 44.1908.574.200 / Fax: 44.1908.574.300
- **Asia/Pacific** Tel: 81.44.844.8296 / Fax: 81.44.844.8298

Visit www.macom.com for additional data sheets and product information.

M/A-COM Inc. and its affiliates reserve the right to make changes to the product(s) or information contained herein without notice.

MASW-003102-13590 Chip Outline Drawing^{1,2}

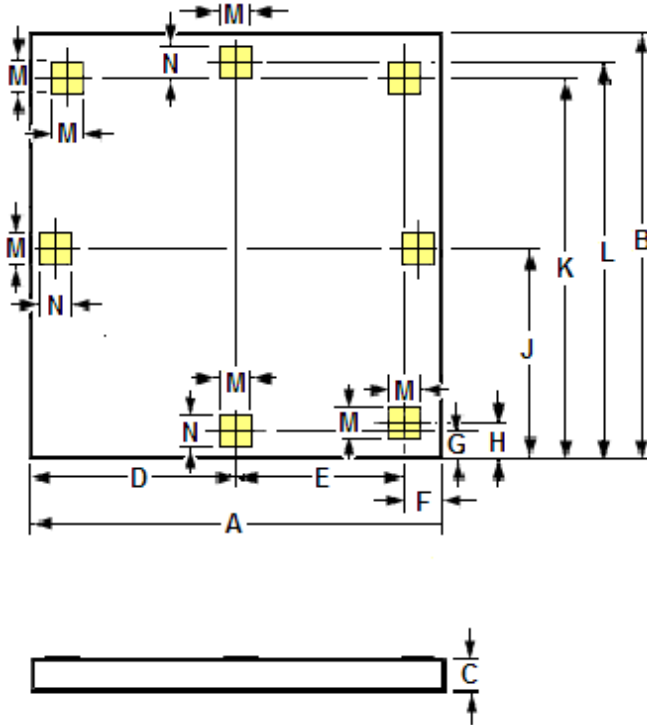

DIM	INCHES		MILLIMETERS	
	MIN	MAX	MIN	MAX
A	0.0697	0.0736	1.770	1.870
B	0.0693	0.0732	1.760	1.860
C	0.0039	0.0059	0.100	0.150
D	0.0310	0.0319	0.787	0.812
E	0.0289	0.0299	0.734	0.759
F	0.0055	0.0075	0.140	0.190
G	0.0035	0.0055	0.089	0.139
H	0.0044	0.0064	0.113	0.163
J	0.0338	0.0358	0.859	0.909
K	0.0632	0.0652	1.610	1.660
L	0.0660	0.0680	1.680	1.730
M	0.0051	REF.	0.1290	REF.
N	0.0046	REF.	0.1180	REF.

Notes:

1. Topside and backside metallization is gold , 2.5mm thick typical.
2. Yellow areas indicate wire bonding pads

Ordering Information

Part Number	Package
MASW-002102-13580G	Gel Pack
MASW-003102-13590G	Gel Pack

ADVANCED: Data Sheets contain information regarding a product M/A-COM is considering for development. Performance is based on target specifications, simulated results, and/or prototype measurements. Commitment to develop is not guaranteed.

PRELIMINARY: Data Sheets contain information regarding a product M/A-COM has under development. Performance is based on engineering tests. Specifications are typical. Mechanical outline has been fixed. Engineering samples and/or test data may be available. Commitment to produce in volume is not guaranteed.

- **North America** Tel: 800.366.2266 / Fax: 978.366.2266
- **Europe** Tel: 44.1908.574.200 / Fax: 44.1908.574.300
- **Asia/Pacific** Tel: 81.44.844.8296 / Fax: 81.44.844.8298

Visit www.macom.com for additional data sheets and product information.

M/A-COM Inc. and its affiliates reserve the right to make changes to the product(s) or information contained herein without notice.